

MODEL: TERREMOTO V2



1/8 SCALE MONSTER TRUCK
OWNERS MANUAL



Fast • Affordable • Fun

MAN-TERREMOTOV2-2015.14.07-V3

•To ensure that you are using the most recent version of this manual:

www.redcatracing.com/manuals/TerremotoManualFinal.pdf

•To ensure that you have the most recent version of the Electronic Vehicles Manual:

www.redcatracing.com/manuals/ELECTRIC-MANUAL.pdf

FEATURES & SPECIFICATIONS

- Powerful 2260KV Brushless Electric Motor
- Brushless Waterproof 80A ESC (LIPO Ready)
- Forward & Reverse
- 4 Wheel Drive
- Big Bore Aluminum Oil Filled Shocks
- Dual Rechargeable 7.4v 3200mAh 20c LIPO Battery Packs **
- LIPO Battery Charger **
- 2.4GHz Radio System
- 15KG Waterproof Metal Gear Steering Servo

**RTR VERSIONS ONLY
 **ARTR VERSIONS DO NOT INCLUDE BATTERIES OR CHARGER

- Scale: 1/8
- Length: 550mm
- Width: 460mm
- Height: 240mm (without body)
- Wheelbase: 376mm
- Ground Clearance: 95mm (adjustable)

Vehicle Battery Capabilities

Minimum: 11.1v total (1pc 3s/11.1v battery pack)

Maximum: 14.4v total (2pcs 2s/7.4v battery pack

OR 1pc 4s/14.4v battery pack)

Warning: Exceeding the maximum battery voltage may cause damage to the motor and electronic components of this vehicle and will void the vehicle warranty.

VEHICLE OVERVIEW

- A:** Oil Filled Shocks
- B:** Steering Servo
- C:** Steering Mechanism
- D:** On/Off Switch
- E:** ESC
- F:** 2.4GHz Receiver
- G:** Electric Motor
- H:** Steering Linkage
- I:** Upper Suspension Link
- J:** Battery Boxes
- K:** Battery Retainer Clips

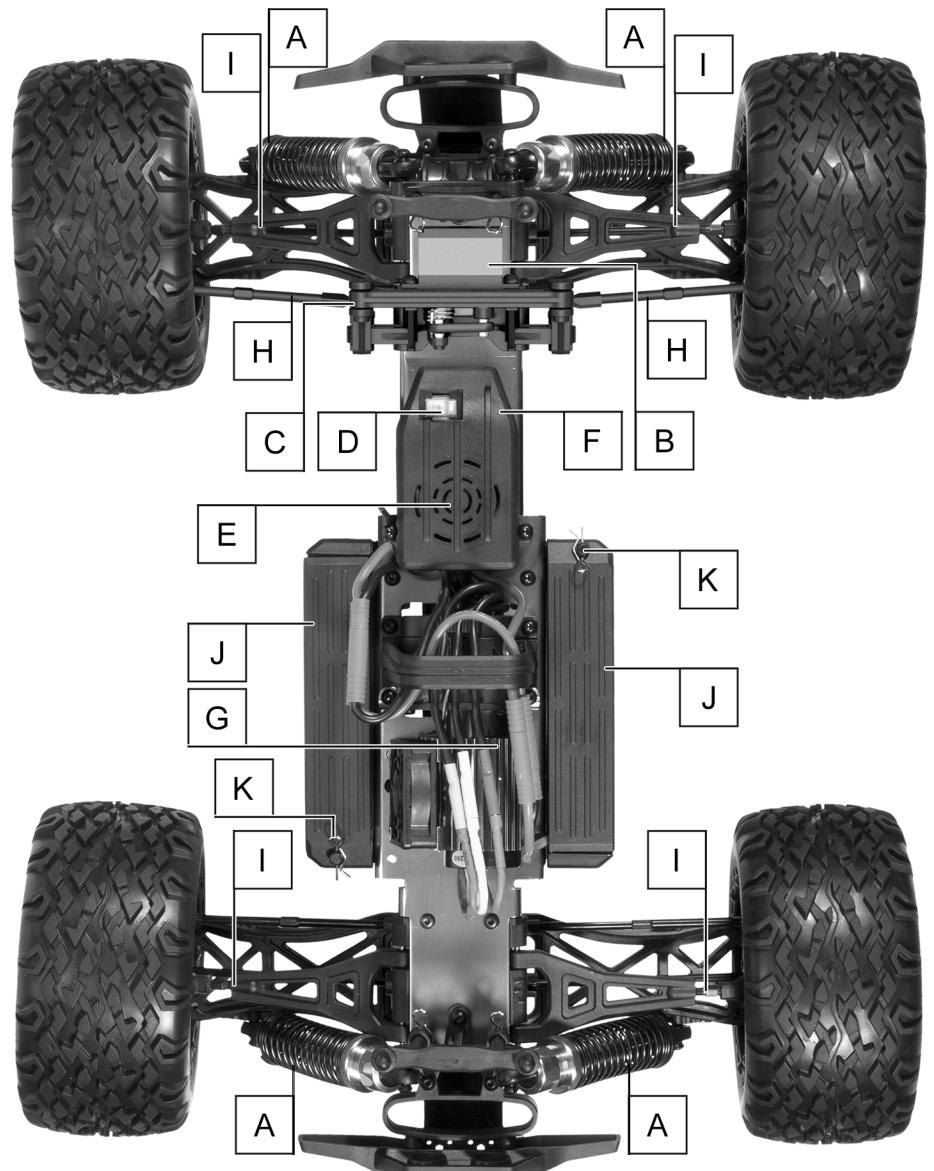

RADIO GUIDE

RCR-2C
 2.4 GHZ RADIO

CONTROL PANEL

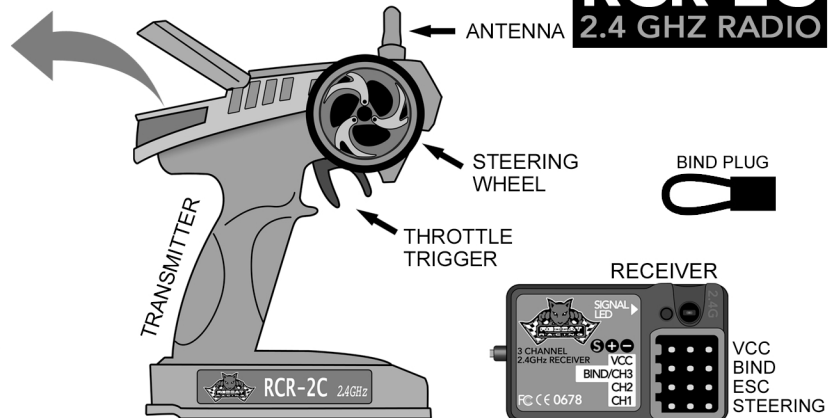

Steering Reverse Switch: Top left switch. Used to change steering orientation. If the car turns right when you steer left, flip this switch.

Throttle Reverse Switch: Top right switch. Used to change throttle trigger orientation. If the car goes in reverse while you pull the throttle trigger, flip this switch.

Power LED: Left LED light. Lights up when the transmitter is turned on.

Battery Level LED: Right LED light. Lights up green when transmitter batteries are full. Flashes when transmitter batteries are low and need replacing.

Bind Button: Used to bind the transmitter to the receiver. See binding instructions.

Steering Trim: Left knob. Used to set the steering neutral point. If the vehicle veers in one direction while the steering wheel is centered, turn this knob in the opposite direction until the car drives straight.

Throttle Trim: Middle knob. Used to set the throttle neutral point. If the vehicle moves forward or reverse while the throttle trigger is centered, turn this knob until the vehicle remains still. For maximum setting, turn slowly until the vehicle creeps forward, then turn the knob the opposite direction until the car stops.

Steering Dual Rate: Right knob. Used to limit the amount of steering. 0= little/no steering & 6= maximum steering. Set the knob to the amount of steering you feel comfortable with. If the vehicle has a tendency to spin out, lower the steering rate.

On/Off Switch: Bottom switch. Turns transmitter On and Off.

VCC: Not used.

Bind/Ch3: Used when binding to transmitter. Used for 3rd channel when needed.

Ch2: Used for Electronic Speed Controller.

Ch1: Used for steering servo.

Binding:

1. Insert the BIND PLUG into the receiver BIND port.
2. Make sure your ESC is plugged into CH2, and insert the bind plug into BIND/CH3. Now, power the vehicle on and the receiver light should begin to blink red.
3. Press the BIND button in the center of the transmitter's Control Panel and turn on radio.
4. Release the bind button when you see the green light on the radio flashing. At this point, your receiver's LED should now be solid red. Turn off the power to your vehicle, as well as the radio.
5. Remove the BIND PLUG from the receiver. Make sure the servos and ESC are attached as described above.
6. First turn your radio on, then your vehicle as normal. Your radio and receiver should be bound together and communicating with each other.

LIPO CHARGER

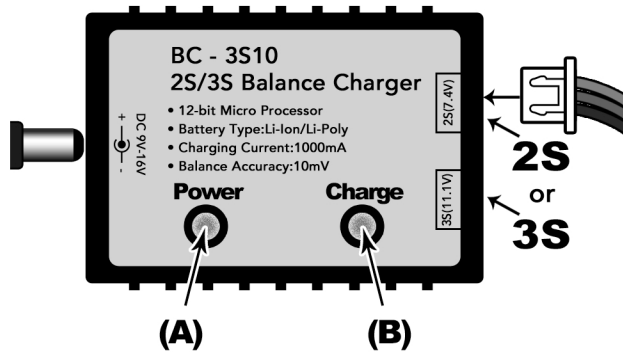

LIPO: The BC - 3S10 Balance charger is capable of charging 2S and 3S LIPO batteries.

DC Port: Single round port on left end of charger. Plug in DC adapter here.

Power LED: Left LED light. Lights up when charger is connected to a 110v power source.

Charge LED: Right LED light. Blinks while battery is charging. LED light will turn solid red when battery is fully charged

2S Port: Used to charge 2S 7.4v LIPO battery packs.

3S Port: Used to charge 3S 11.1v LIPO battery packs.

Charging Instructions:

1. Unplug the battery pack from the ESC and remove the battery from the vehicle.
2. Plug the charger into a 110v power receptacle using the included DC power adapter. Power light will be on.
3. Plug the 2S/3S LIPO battery "balance charge plug" into the appropriate charge port. (as seen above) - Charge light will blink while the LIPO battery is charging.
4. When the charge light turns solid red, unplug the battery as charging is complete.
5. Unplug charger from the 110v power source.

- ATTENTION -

Battery and charger are only included with the RTR version! If you purchased item number: TERREMOTO-BLUE-NOBATTERIES-NOCHARGER you will not have a battery or charger in your box. Please read all instructions that came with the battery and charger you plan to use.

- ATTENTION -

When plugging the battery pack into the ESC, make sure the plugs are lined up correctly!

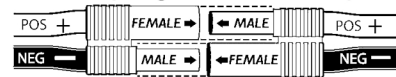

Ensure POS+ wire is connected to POS+ & NEG- is connected to NEG-

STOP

WARNING

STOP

UNPLUG THE BATTERY PACK FROM THE VEHICLE!

BEFORE CHARGING YOUR BATTERY PACK, YOU MUST FIRST UNPLUG IT FROM THE ESC. FAILURE TO UNPLUG THE BATTERY FROM THE VEHICLE'S ESC BEFORE CHARGING MAY PERMANENTLY DAMAGE SOME OR ALL ELECTRONICS IN THE VEHICLE.

NEVER LEAVE BATTERY PACKS UNATTENDED WHILE CHARGING! Leaving a battery unattended while charging may result in fire and damage / injury.

NEVER ALLOW A BATTERY PACK TO GET HOT! It's normal for the battery pack to get warm, but it should never get hot! Monitor batteries during charging and unplug to let cool if the battery gets hot.

WHEN CHARGING LIPOs, A LIPO SAFE CHARGING BAG SHOULD BE USED TO HELP PREVENT FIRES.

Exploded View - Terremoto V2

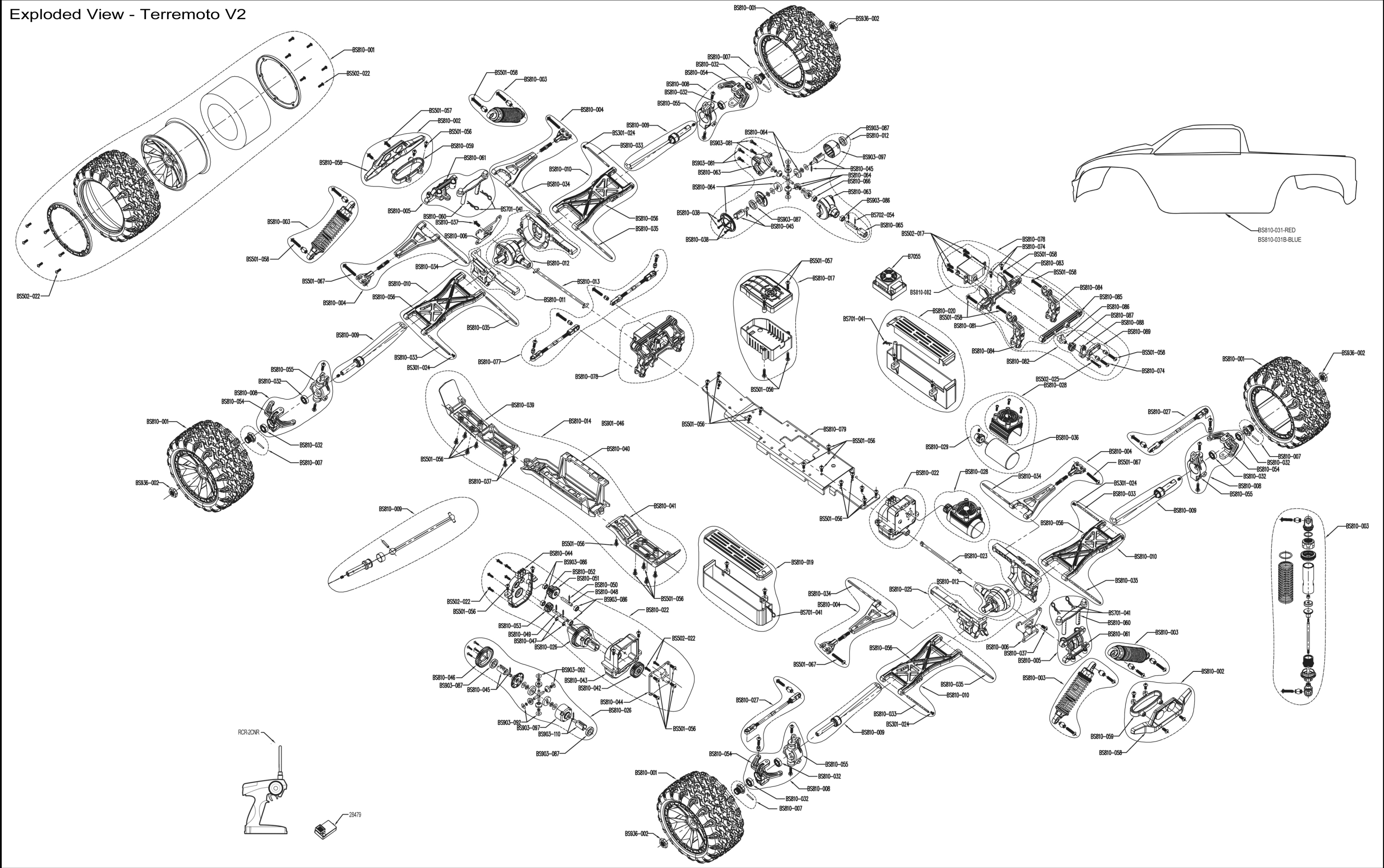

PARTS IDENTIFICATION

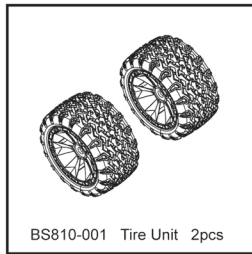

BS810-001 Tire Unit 2pcs

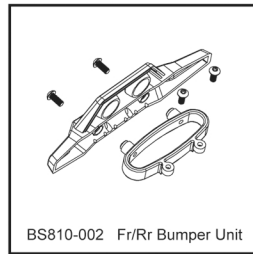

BS810-002 Fr/Rr Bumper Unit

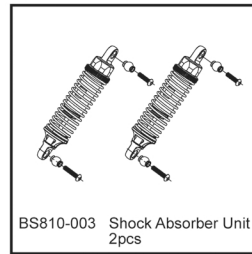

BS810-003 Shock Absorber Unit 2pcs

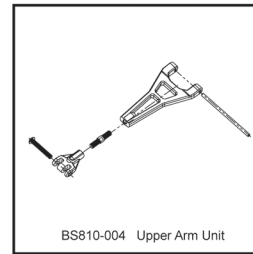

BS810-004 Upper Arm Unit

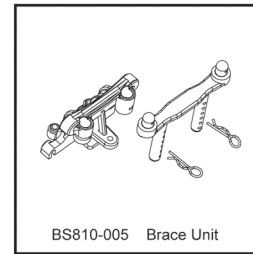

BS810-005 Brace Unit

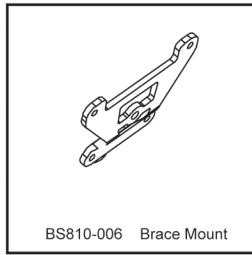

BS810-006 Brace Mount

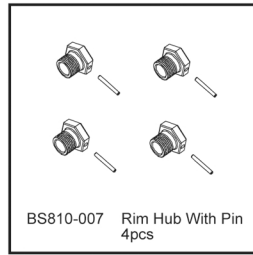

BS810-007 Rim Hub With Pin 4pcs

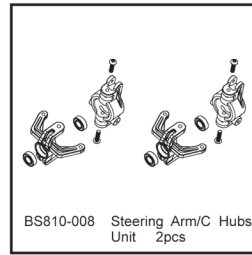

BS810-008 Steering Arm/C Hubs Unit 2pcs

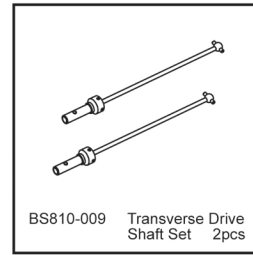

BS810-009 Transverse Drive Shaft Set 2pcs

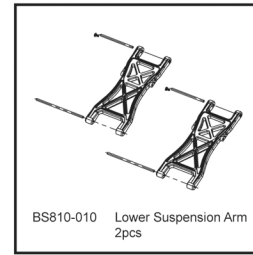

BS810-010 Lower Suspension Arm 2pcs

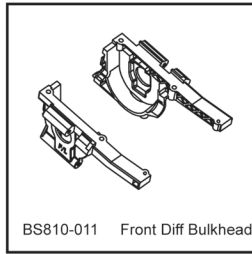

BS810-011 Front Diff Bulkhead

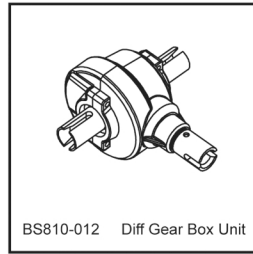

BS810-012 Diff Gear Box Unit

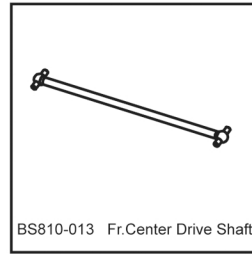

BS810-013 Fr.Center Drive Shaft

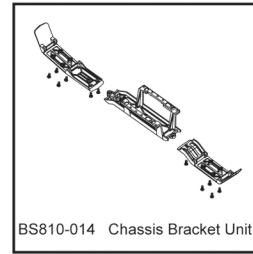

BS810-014 Chassis Bracket Unit

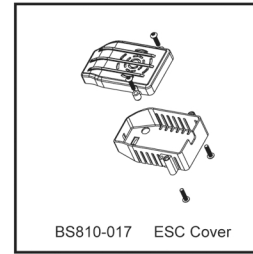

BS810-017 ESC Cover

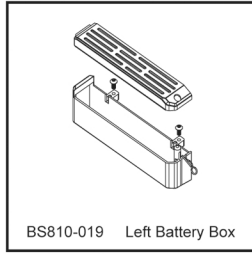

BS810-019 Left Battery Box

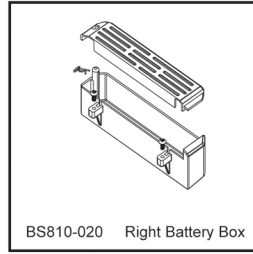

BS810-020 Right Battery Box

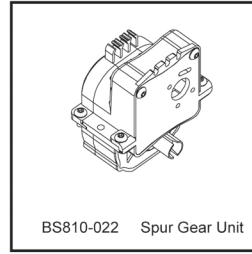

BS810-022 Spur Gear Unit

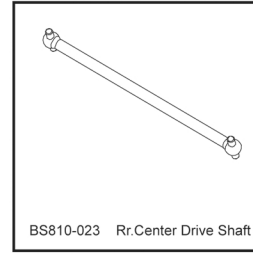

BS810-023 Rr.Center Drive Shaft

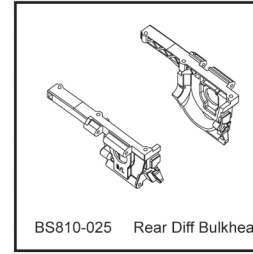

BS810-025 Rear Diff Bulkhead

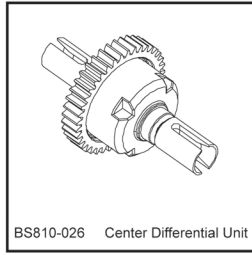

BS810-026 Center Differential Unit

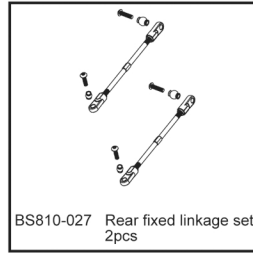

BS810-027 Rear fixed linkage set 2pcs

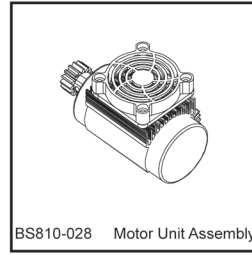

BS810-028 Motor Unit Assembly

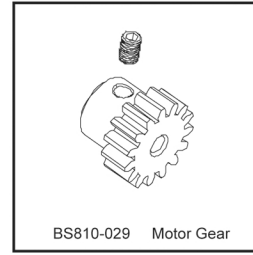

BS810-029 Motor Gear

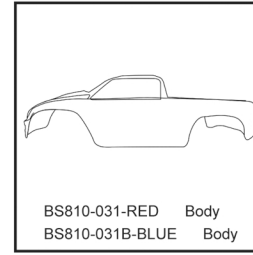

BS810-031-RED Body
BS810-031B-BLUE Body

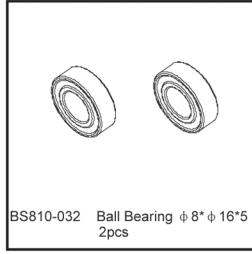

BS810-032 Ball Bearing $\phi 8 \times \phi 16 \times 5$ 2pcs

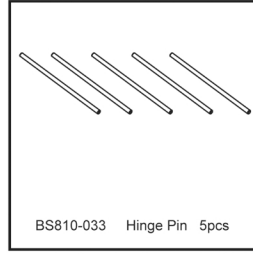

BS810-033 Hinge Pin 5pcs

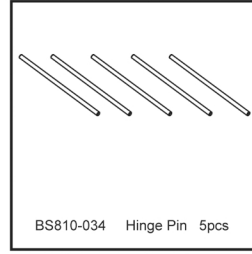

BS810-034 Hinge Pin 5pcs

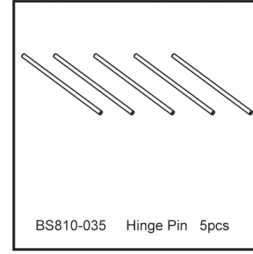

BS810-035 Hinge Pin 5pcs

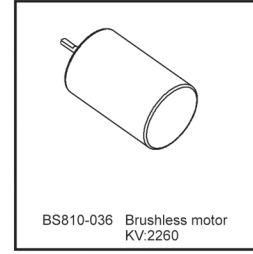

BS810-036 Brushless motor KV:2260

PARTS IDENTIFICATION

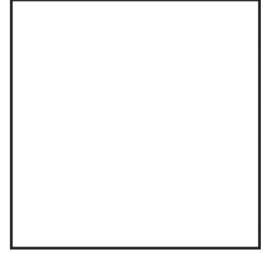
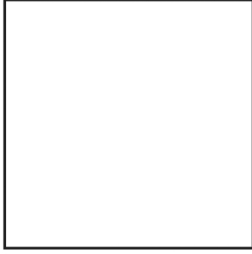
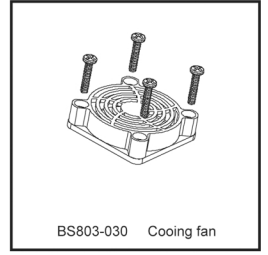
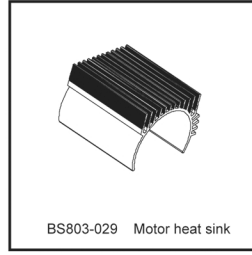
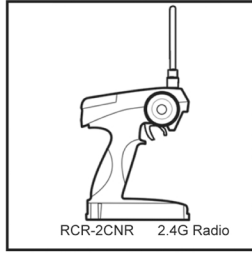
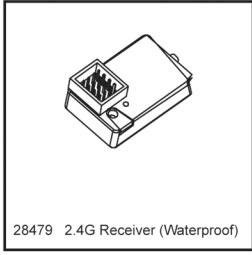
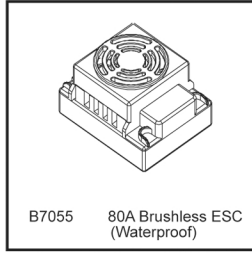
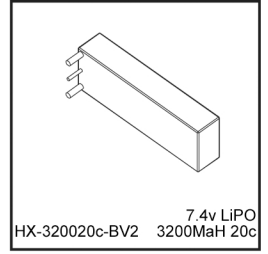
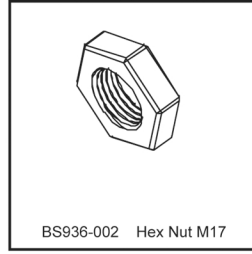
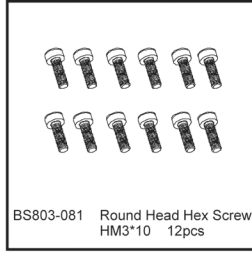
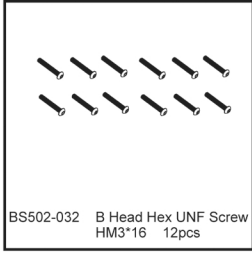
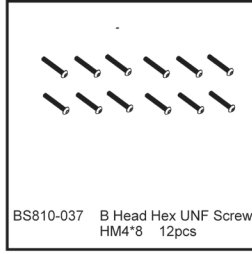
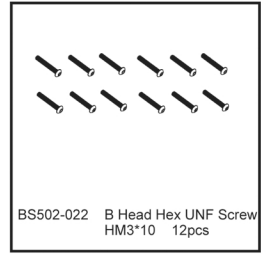
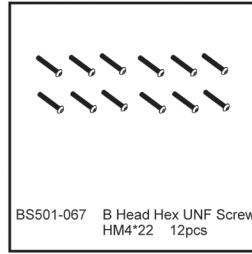
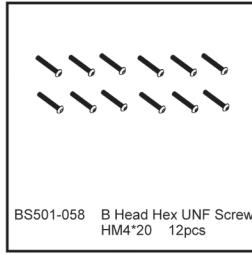
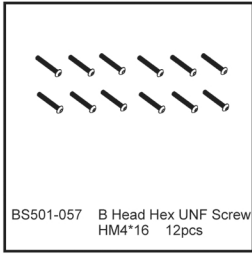
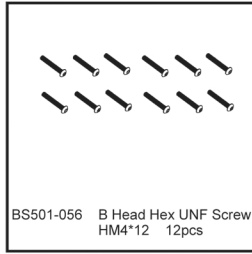
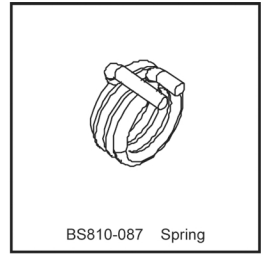
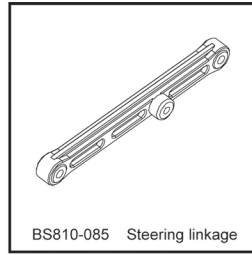
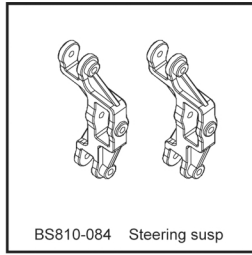
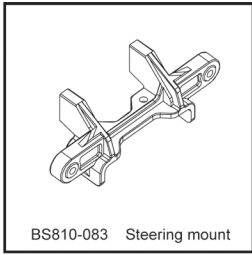
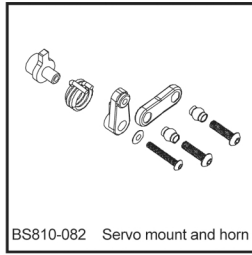
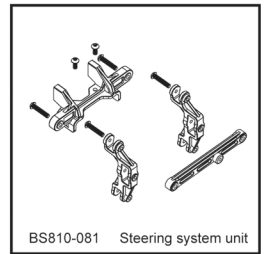
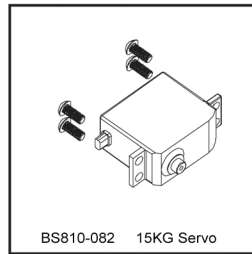
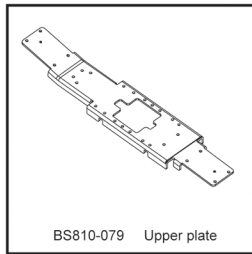
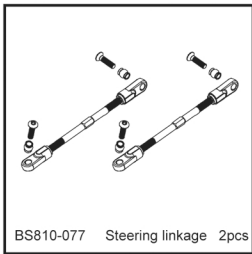
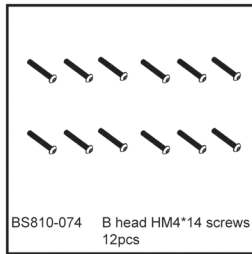



FAST  AFFORDABLE  FUN

www.redcatracing.com

MAN-TERREMOTOV2-2015.14.07-V3

•To ensure that you are using the most recent version of this manual:

www.redcatracing.com/manuals/TerremotoManualFinal.pdf

•To ensure that you have the most recent version of the Electronic Vehicles Manual:

www.redcatracing.com/manuals/ELECTRIC-MANUAL.pdf